

**Choose Roller Assembly**

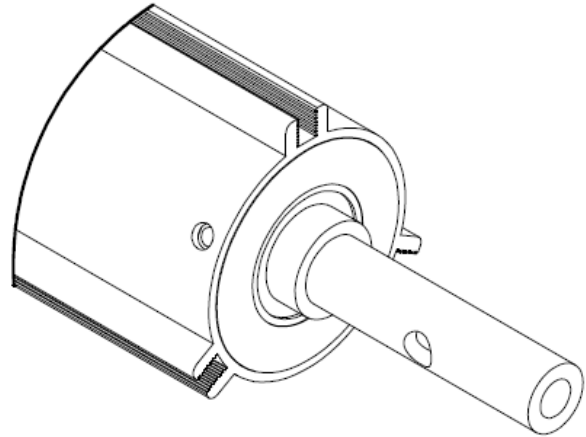
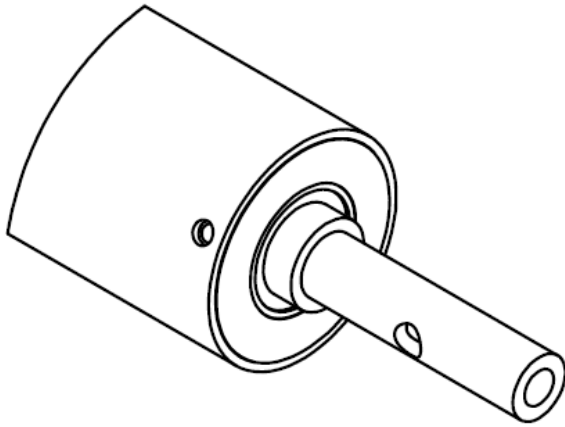

**H7022C– Spring Roller Assembly**

**H7002A– Aluminum Roller Tube**

**A: Pin to Pin Measurement:** \_\_\_\_\_

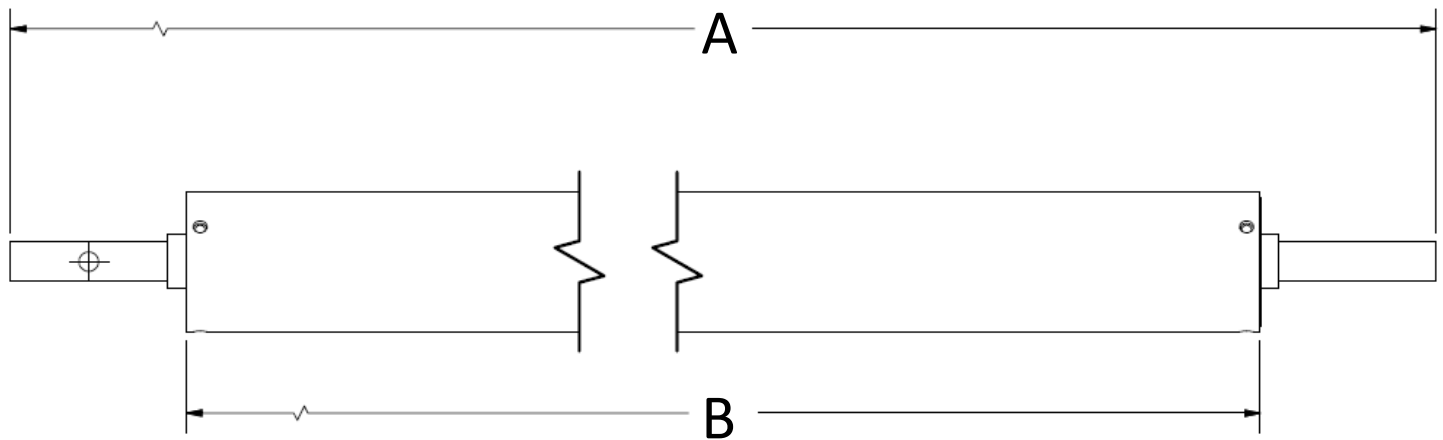

**B: End to End Measurement:** \_\_\_\_\_

**Notes:-**

---



---



---

**STEP 4: Contact Info**

Name: \_\_\_\_\_

Company: \_\_\_\_\_

Location: \_\_\_\_\_

Phone: \_\_\_\_\_

Email: \_\_\_\_\_