

Order

 Quote

## STEP 1: Trailer Details and Measurements

### Trailer Measurements

Outside Length: \_\_\_\_\_ (in)  
 Inside Length: \_\_\_\_\_ (in)  
 Outside Width: \_\_\_\_\_ (in)  
 Inside Width: \_\_\_\_\_ (in)  
 Side Wall Height: \_\_\_\_\_ (in)

 Dump Door

### Corner Configuration

 Square  Diagonal  Radius

### Corner Dimensions

C Flat Across Front: \_\_\_\_\_ (in)  
 D Flat Across Diagonal: \_\_\_\_\_ (in)  
 E Diagonal Depth: \_\_\_\_\_ (in)  
 F Outside Corner Radius: \_\_\_\_\_ (in)

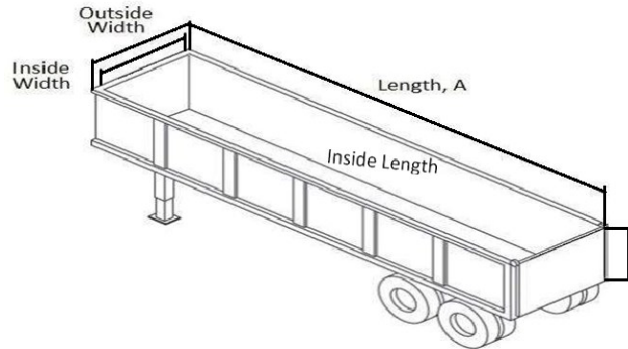

\*Tapered trailers are dimensioned similar to the above picture

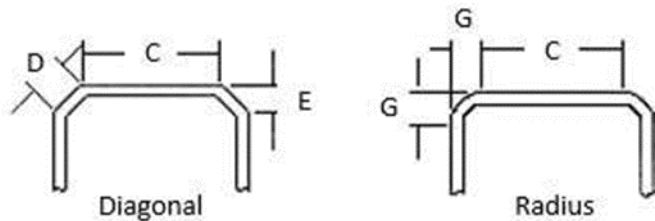

## STEP 2: System Options

To order end caps please fill out separate End Cap Ordering Form.  
 \* Marks standard options

### Tarp Material

 Black Mesh  18oz. Black Vinyl  
 Monster Mesh  22oz. Black Vinyl  
 Armor Mesh

### Tarp Stop Upgrades

 Extruded Alum. \*  Flex Stop  
 Cast Alum.  Flex Stop 6" Offset  
 Cast Alum. 6" Offset

### Ridge Strap

 1" \*  
 2"

### Bow Options

 Low Rise Alum. Bows \*  
 High Rise Alum. Bows  
 Alum. Mounting Flex Bows  
 Steel Mounting Flex Bows

### Crank Retainer Upgrades

 7" Offset J-Hook \*  
 7" Offset Pin-less  
 Spring Latch Pin-less  
 J-Hook

### Crank Upgrades

 Flex Crank Arm (8" Adjust)  Crank Arm (12" Adjust)\*  
 6' Long  
 7' Long  
 Custom Length Flex: \_\_\_\_\_

## Contact Info:

Name: \_\_\_\_\_  
 Company: \_\_\_\_\_  
 Location: \_\_\_\_\_  
 Phone: \_\_\_\_\_  
 Email: \_\_\_\_\_