

## How To Replace H7002A/H7002C Roll Tubes



1. Layout tarp with vinyl reinforcement facing down
2. Set roll-tube on top of tarp at the rear. There will be grommets on the back edge of the tarp.
3. Ensure that the labeled driver side of the roll tube is laying on the left-hand side of the tarp

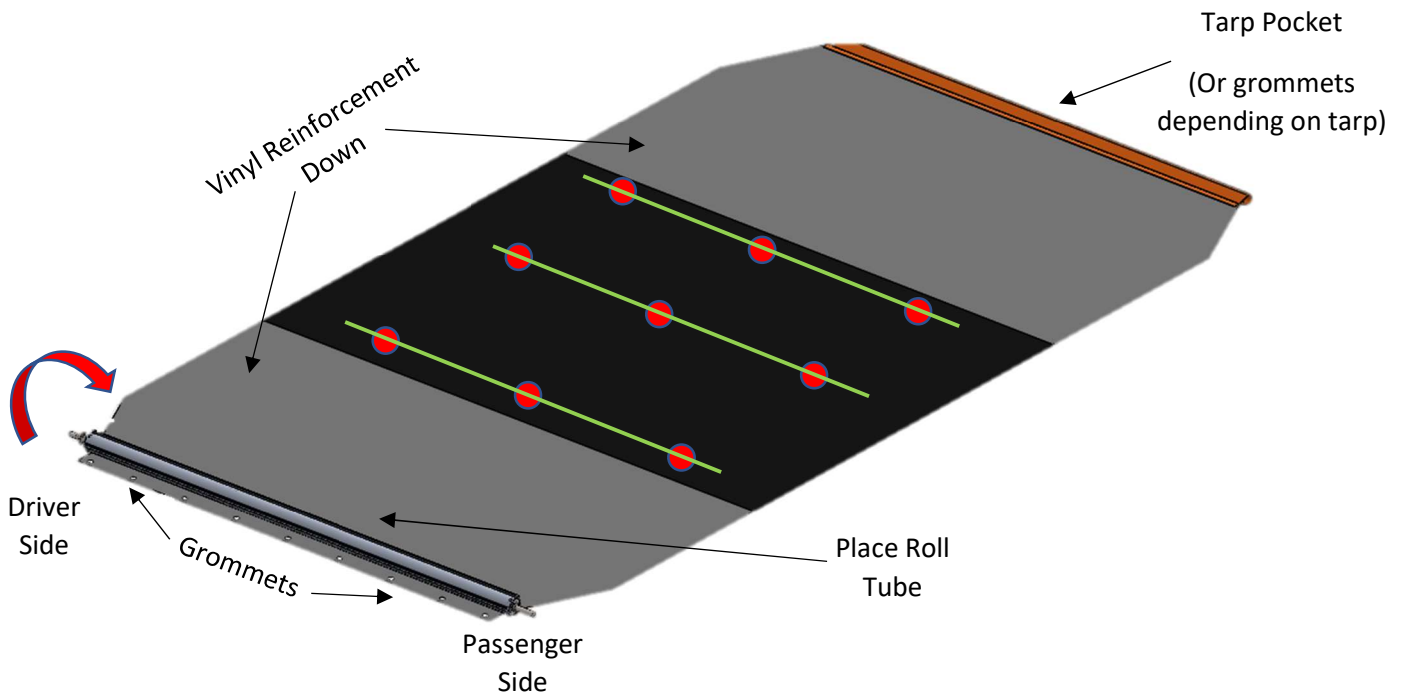

Figure 1 – Tarp/Roll Tube Orientation

4. Using 3/8" Hex bolts (or #12 self-tapping screws for smooth steel roll tubes), fix tarp to roll tube bolting through the grommets.
5. Roll Tarp onto tube according to arrow in Figure 1. Leave 6-8" of tarp unraveled.

6. Set roll tube on roll rest. Slide stationary tarp tube in to tarp pocket (or self-tap to tarp tube for older tarp styles). See Figure 2.

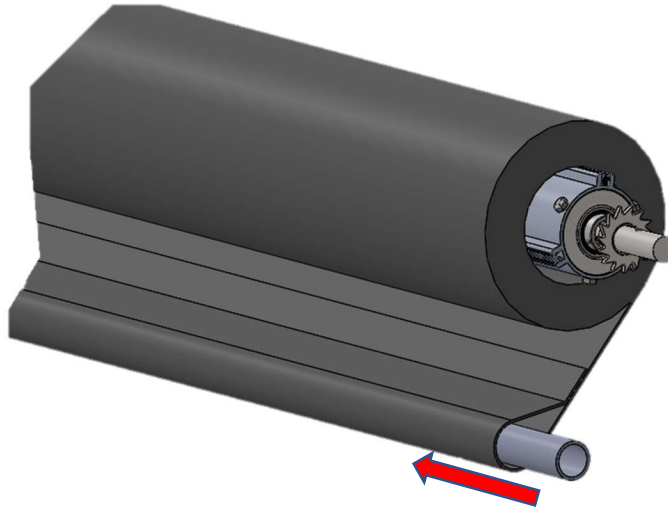

Figure 2 – Inserting Stationary Tarp Tube

7. Re-bolt stationary tarp tube back under roll rest. Slide one shaft collar from old roll tube on passenger side roll tube shaft.
8. Insert roll tube shaft into arms. This will require the removal of the stabilizer bar. See Figure 3.
9. Once inserted, re-attach stabilizer bar.

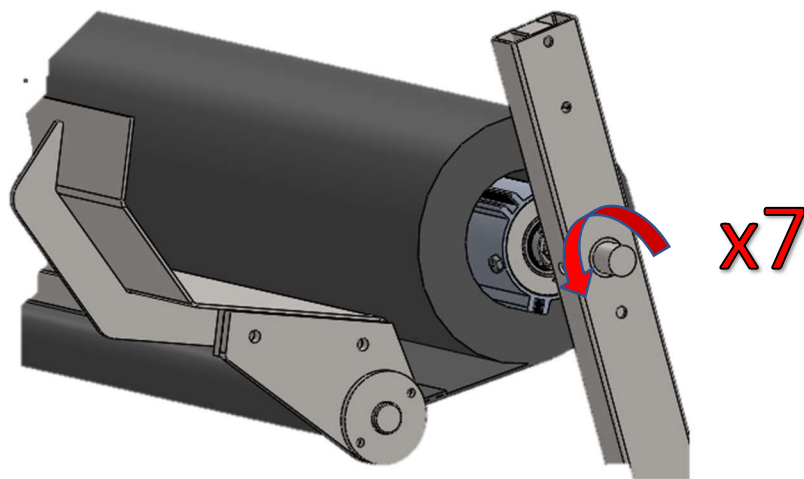

Figure 3 – Inserting Roll Tube Shaft into Arms

10. Attach winding disk or use pipe wrench to pre-tension roll tube shaft 7 turns.

11. Once pre-tensioned, insert the 3/8" hex bolt through the arm and roll tube shaft. Remove winding disk or pipe wrench. See Figure 4.

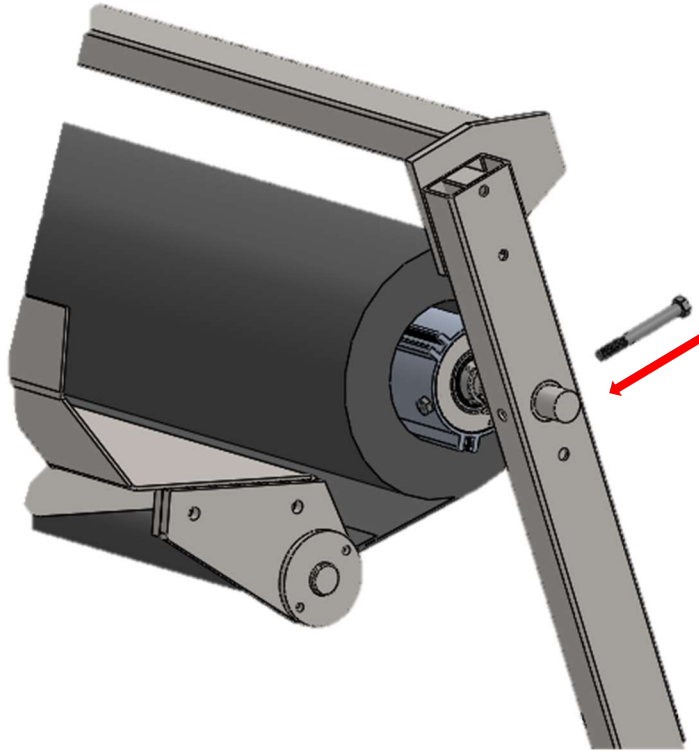

Figure 4 – Inserting Shaft Bolt

12. Slide second shaft collar on passenger side roll tube shaft sandwiching passenger side extension arm. Tighten set screws on both shaft collars.
13. Run system in and out to check functionality of new roll tube.

**P: 800-249-0297 | F: 269-639-3015 | E: [technicalsupport@ustarp.com](mailto:technicalsupport@ustarp.com)**